

Utfärdare Issued by Aussteller	Bertil Nyström	Datum Date Datum	2006-04-07	Produkt Product Produkt	Scando
Från maskin nr. From machine No. - Von Maschine Nr.		Till To - Zu		Berör/Concerns/Betrifft	Guide roller

Guide roller Part No. 9042814-000 and 9019738-000

The wear limits for the guide roller shall always be followed.

Besides that the diameter will be reduced at hard use, the roller side edges may also be unevenly worn, if the axial movability (+/- 3 mm) should not work satisfactorily.

Unload the roller pressure and check the axial movement.

See attached picture from the Operation and Maintenance Manual:

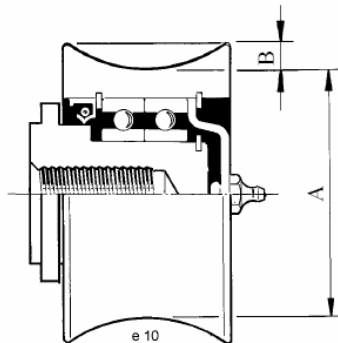

Guide roller

Measure with sliding calipers.

Dimensions	New roller (mm)	Worn-out roller (mm)
A	Ø 74 (Ø 2.91 in.)	min. Ø 68 (min. Ø 2.68 in.)
B		min. 4 (min. .157 in.)

Note that the "wearing" on the roller face must be equal – all around.

ALIMAK 32280 -1/08

Please forward this instruction to all people concerned before inserting it in your Service Manual under index 2, Service Instructions!

Form approved by Anders Nilsson, After Sales Manager. Date: 2005-02-28

Alimak AB

Please forward this instruction to all people concerned before inserting it in your Service Manual under index 2, Service Instructions!

Form approved by Anders Nilsson, After Sales Manager. Date: 2005-02-28