

Utfärdare Issued by Aussteller	Bertil Nyström	Datum Date Datum	2005-10-24	Produkt Product Produkt	Scando Mini 4/9 and Alicom 400
Från maskin nr. From machine No. Von Maschine Nr.	-	Till To Zu	-	Berör/Concerns/Betrifft	Safety device

Safety devices for Scando Mini 4/9 and Alicom 400

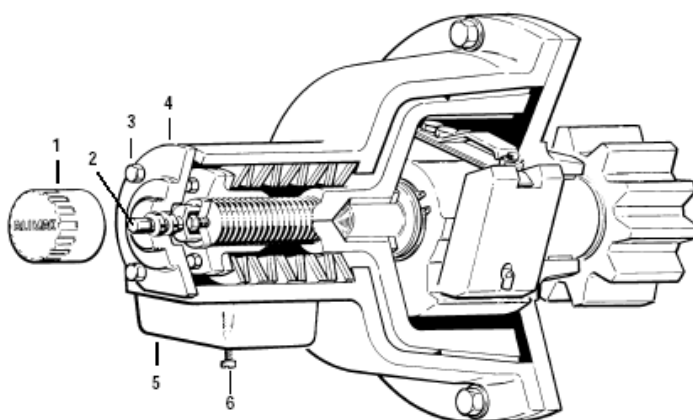

The safety devices for these lift types have been equipped with a device having a far too hard setting of the spring force. Result: the electrical switch has not always cut off the safety circuit signal during a tripping situation.

The existing safety device at 50 Hz power supply has part No. 0183144-151. This is now replaced by part No. 0183144-153, which has a lower presetting.

The existing safety device at 60 Hz power supply has part No. 0183144-172. This is now replaced by part No. 0183144-173, which has a lower presetting.

Important!

When ordering an exchange safety device for the above-mentioned lift types the serial No. (= manufacturing No.) of the lift shall be noted in the order specification.

Please forward this instruction to all people concerned before inserting it in your Service Manual under index 2, Service Instructions!

Form approved by Anders Nilsson, After Sales Manager. Date: 2005-02-28