



# PLM

Personnel/material hoist

**Mastclimbing workplatforms** a versatile working environment above ground level. The alternative to traditional scaffolding and suspended systems. Single or twin mast versions with platform lengths of 2.7 m to 32.6 m. Working heights of up to 200 m, lifting capacity up to 4,000 kg.



**Total support services** to ensure full customer satisfaction. The worldwide HEK organisation (HEK (regional) offices, subsidiary companies and an excellent dealer network) provide a complete range of customer services - pre-sales, sales, rental, assembling and dismantling, transport and maintenance, training and technical support (calculations, tailor-made solutions, special constructions, working drawings) as well as online services. The best service available from start to finish - that's HEK! Why not ask our customers?

**Transport platforms** for transporting bulky and heavy loads. Developed for vertical transportation of goods and people up to a height of 120 m. Payloads of 500 kg (incl. 3 persons) and 1,750 kg (incl. 7 persons).



**Personnel/material hoists** fast transportation of people and goods. Suitable for both small and large projects, up to a height of 200 m. The hoists require minimum maintenance and meet the strictest safety standards in this field.



## HEK, market leader in mastclimbing workplatforms

**Save costs by working efficiently**  
Fast assembly, plenty of room to work on the platforms and rapid and energy-saving transportation of personnel and materials mean that projects can be carried out efficiently and economically.

**Safety and durability**  
HEK's high quality is based on more than 40 years experience in developing and producing mastclimbing workplatforms. The use of first class materials, a high degree of precision due to automated production and sturdy constructions provide a guarantee of safety and durability.

**Extensive standard package and custom work**  
HEK is not without reason world leader in mastclimbing workplatforms. For almost any project, HEK can offer a suitable solution for working above ground level and for vertical transportation of materials and/or people.

**Material hoists** efficient transportation of goods for smaller projects. These durable and robust material hoists are easy to transport and assemble. With payloads up to 500 kg and a maximum working height of 80 m.



internet [www.HEK.com](http://www.HEK.com)  
e-mail [info@HEK.com](mailto:info@HEK.com)



**HEK Manufacturing B.V.**  
P.O. Box 2, 5090 AA Middelbeers  
The Netherlands  
Telephone (+31) 13 514 86 53  
Telefax (+31) 13 514 86 30  
**HEK Nederland B.V.**  
Telefoon (+31) 13 514 86 00  
Telefax (+31) 13 514 86 10  
**HEK Hebetchnik GmbH**  
Telefon (+49) 7262 9149 0  
Telefax (+49) 7262 9149 50  
**HEK France SAS**  
Téléphone (+33) 3 44 26 85 00  
Téléfax (+33) 3 44 26 85 01  
**HEK Platforms & Hoists Inc.**  
Telephone (+1) 770 917 0425  
Telefax (+1) 770 917 0614

HEK Manufacturing B.V. is  
ISO-9001 approved

a ThyssenKrupp Company

Applications, configurations, technical data and working procedures are for illustration purposes only. According to (inter)national and/or local legislation and regulations they may not be permitted in certain cases; buyer or lessee should verify local regulations in its jurisdiction. Further, we reserve the right to change any of the aforementioned concerning our products in this brochure at any time without prior notice.

BE0 020 05-00 PLM ENG - PRINTED ON ECOLOGICALLY BENEFICIAL PAPER



## **HEK PLM**

### **Flexibility thanks to modular structure**

HEK's PLM hoists not only distinguish themselves by their quality, durability and safety, but also through their unique modular structure. In practical terms, this means that the PLM can be customized and adapted to fit specific circumstances, for example, inside elevator or stair cores. This flexible, well-designed system guarantees optimum efficiency and trouble-free progress for all on-site activities, saving both time and money. With a payload capacity of 2,000 kg and a safe working height of 200 meter, the PLM is ideal for the effective transport of personnel and materials on construction sites and for repairs and maintenance on industrial installations. The 4 meter cage length will easily carry 3.90 meter plasterboard or other panels. And again, since the PLM is a modular unit, it may be used in locations where other hoists couldn't be installed.

The PLM's unique features and characteristics display the expertise that HEK has earned over the years, and underscore the company's innovative and customer-oriented approach. In HEK, you have an experienced, reliable and flexible partner.

# Unique modular system



Modules with wire mesh or lexan (optional).



### Safety and reliability

Besides efficiency and cost saving aspects, HEK pays a great deal of attention to safety, durability and reliability during the development and construction of hoists and mastclimbing work-platforms. PLM personnel/material hoists meet the most stringent requirements in the world, and are designed to be easy and efficient to operate. The control panel is well organized and user-friendly. The hoists are powered by extremely reliable motors, which make counterweights obsolete, permitting the PLM to start and stop much more smoothly and precisely than the counterweighted machines and similar hoists. Less time is spent at each stop, putting crews to work faster – and saving wear and tear on the motor drive and braking systems.

HEK personnel/material hoists are also equipped with a separate failsafe brake and an automatic two-way overload prevention system. The PLM is not only protected against overloading during operation in either the up or down direction, but in the static position as well. The control system will not permit operation when the hoist is overloaded, distinguishing the HEK PLM series as one of the safest hoists in the world.

The structural design and use of high-quality materials means the PLM's require less maintenance and provide more reliability – which keeps them working – allowing construction workers to concentrate on their work without unnecessary delays. The twin version of the PLM with two independently operating cages speeds up the work even more.



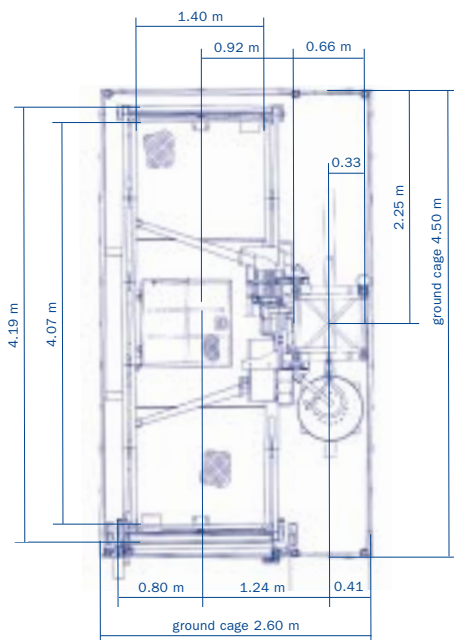
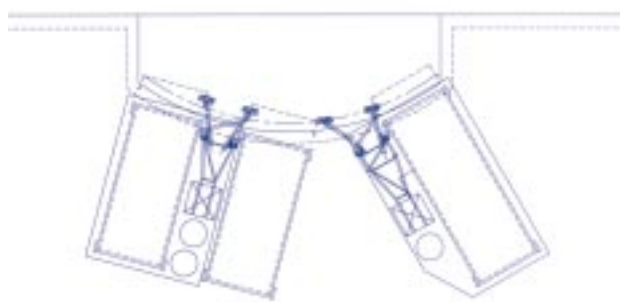
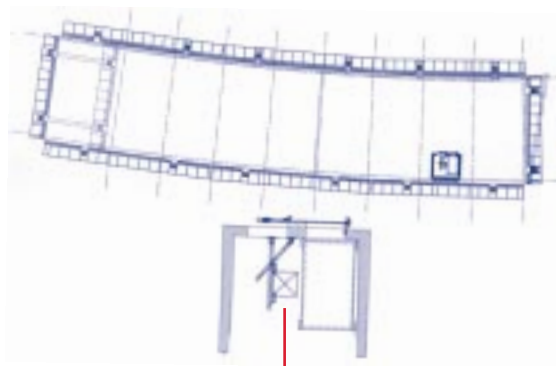

**Benefits:**

- Safe, fast, reliable transport of personnel and materials
- Long working life due to durable construction – quality you can see
- Manufacturing certified to ISO 9001 quality control requirements
- Smooth, precise stops at landings – saves time – saves wear
- Surprisingly quiet operation thanks to the nylatron rollers
- Galvanised mast and structure
- Genuine HEK machine with genuine HEK service

**Characteristics:**

- Flexible applications due to unique modular system
- Meets or exceeds the toughest safety requirements
- Single-cage or twin-cage versions
- Multi-purpose operation
- Reliable and user-friendly



The PLM series	PLM 1000	PLM 1500	PLM 1500	PLM 2000 single	PLM 2000 twin
Cabin dimensions (m):	1.6/2.4x1.4	2.4/3.2x1.4	2.4x1.4	3.2/4.0x1.4	3.2/4.0x1.4
Mast type:	square	square	square	square	square
	500/500	500/500	700/700	700/700	700/700
Payload (kg):	1000	1500	1500	2000	2 x 2000
No. of people:	12	18	18	25	2 x 25
Travel speed (m/min):	40	40	40	40	40
No. of Motors:	2	3	3	3	2 x 3
Controls:	autom.	autom.	autom.	autom.	autom.
Max. height (m) with standard mast sections:	200	200	200	200	200
Max. anchoring dimensions (m):	12	12	12	12	12/9
Internal:					2 cages