

ALIMAK

SCANDO® M 1200, M 1500 & M 2000

Technical Data

CAPACITY		SCANDO			
		M 1200	M 1200	M 1500	M 2000
Pay-load capacity	kg	1200	1200	1500	2000
Erection load	kg	1200	1200	1500	2000
Speed 50 Hz/60 Hz	m/min	28	28	28	28
Max. lifting height	meter	100	100	100	100
Increased lifting height on request					
Erection crane capacity	kg	75	150	150	150
Safety device	type	GF	GF	GF	GF

CAGE & BASE FRAME DIMENSIONS

Internal width x length	meter	1.3 x 2.0			
Measure A	meter	2.18	2.24	2.24	2.24
Measure B	meter	2.34	2.16	2.16	2.16

ELECTRICAL DATA

Power supply range	380 – 690 V, 50 or 60 Hz, 3 Phase				
At 400 V/50 Hz:					
Power supply fuses	A	35	35	63	63
Rated power cont. duty	kW	7.5	7.5	2 x 7.5	2 x 7.5
Rated power 25% int. duty	kW	9.5	9.5	2 x 9.5	2 x 9.5
Starting current	A	100	100	200	200
Power consumption	kVA	13	13	26	26

Data at other voltages on request

WEIGHTS

Base unit weight	kg	900	1050	1300	1450
1508 mm long mast section	kg	72	130	130	130

Optional equipment: Ground enclosure

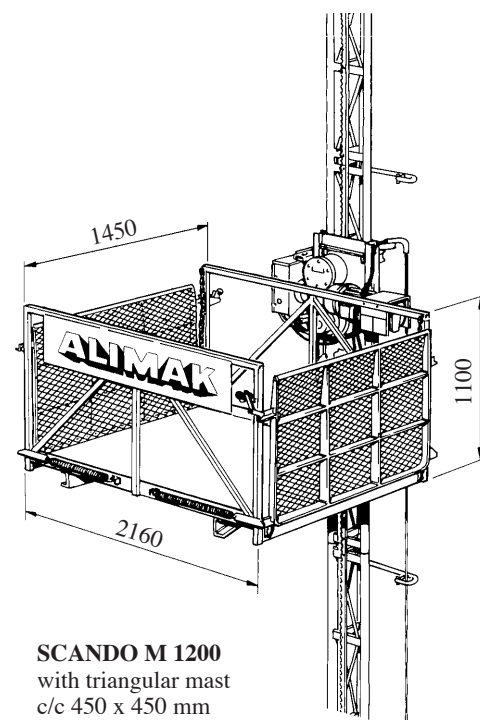
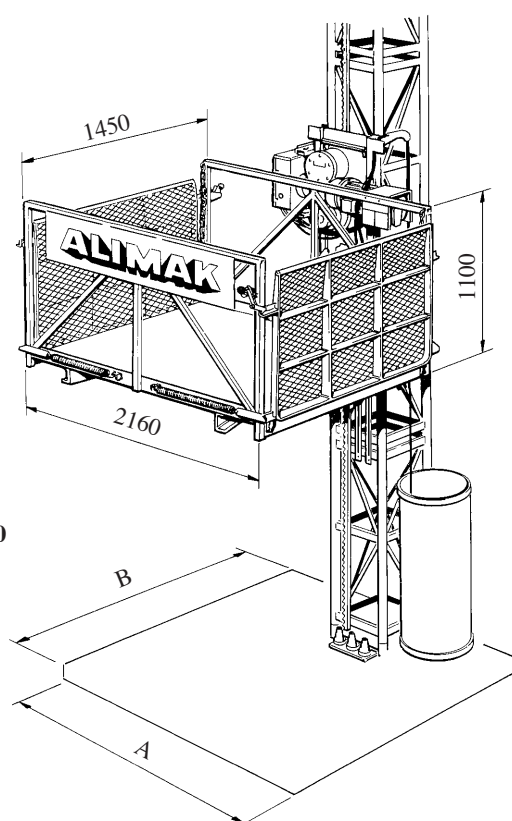
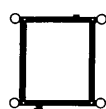
SCANDO M 1200
with triangular mast
c/c 450 x 450 mmSCANDO M 1200, M 1500 & M 2000
with square mast c/c 650 x 650 mm



MEMBER OF THE ATLE KAROLIN GROUP

Alimak AB, P.O. Box 720, S-931 27 Skellefteå, Sweden.
Tel. +46 910 87000. Fax +46 910 56690.
E-mail: info@alimak.se Internet: <http://www.alimak.se>

Alimak have subsidiaries in: Great Britain, Germany, France, USA, Canada, Australia, Singapore, Brazil, Italy as well as in South Korea and, furthermore, 40 independent distributors around the world.