

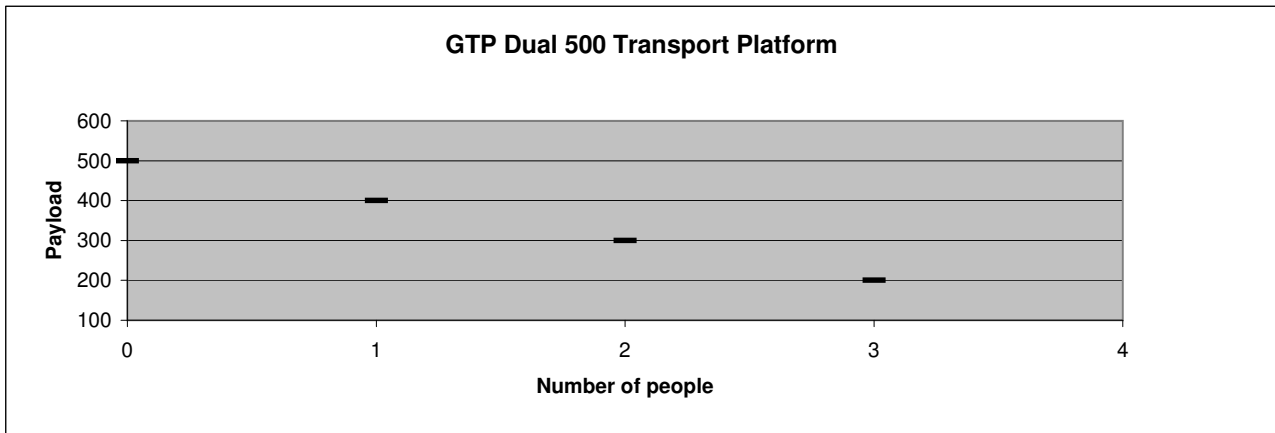

# HEK Manufacturing BV



Technical Data		Transport	Material
Capacity		Platform	General Hoist
Platform dimensions	m	1,6 / 1,25	
Max Payload capacity	kg	500	
Speed	m/min	12	24
Number of people	Qty	1 - 3	Forbidden
Operated from		From platform	Remote control
Max lifting height untied on groundframe	m	0	
Max lifting height tied	m	120	
Tie distance	m	4 - 6	
Max mastheight above last anchor	m	3	

Dimensions and weights			
Outside dimensions: length	m	2,37	
width	m	2,25	
Height to platform	m	0,40	
Basic machine weight	kg	800	
Dimensions mast section (Length x width x depth)	mm	1508 x 400 x 315	
Weight mast section	kg	50	
Mast bolts	Type	M14 x 90 qual. 8,8	
Mast bolt torque	Nm	100	

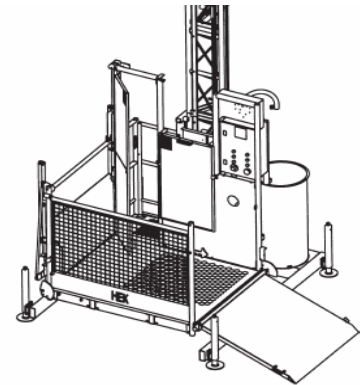

Electrical Data				Safety equipment
Rated power	kW	1x 4,5		Electrically protected mast guard
Voltage	V	370 - 420		Mechanical protection safety barrier
Control Voltage	V	24 / 42		Electrically protected mast lifting aid
Motorbrakes	VAC	230		Manual brake release in emergency
Power supply fuses	V	220		(Ultimate) Upper limit switch
Control Voltage Frequency	Hz	50		(Ultimate) Lower limit switch
Building site fuse (slow)	A	16	32	Centrifugal brake
Nominal / Starting current	A	10,3 - 50	13,2 - 65	Electrical protection loading ramp
Power consumption	kVa	6,5	8,5	Overload protection

HEK Manufacturing BV, PO Box 2, 5090 AA Middelbeers, The Netherlands

Tel: +31 (0) 13 514 8653, Fax: +31 (0)13 514 8630

E-mail: info@HEK.com, Web site: www.HEK.com